

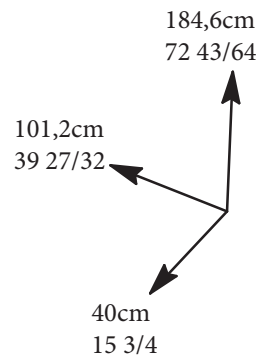

BUFFET DE CUISINE

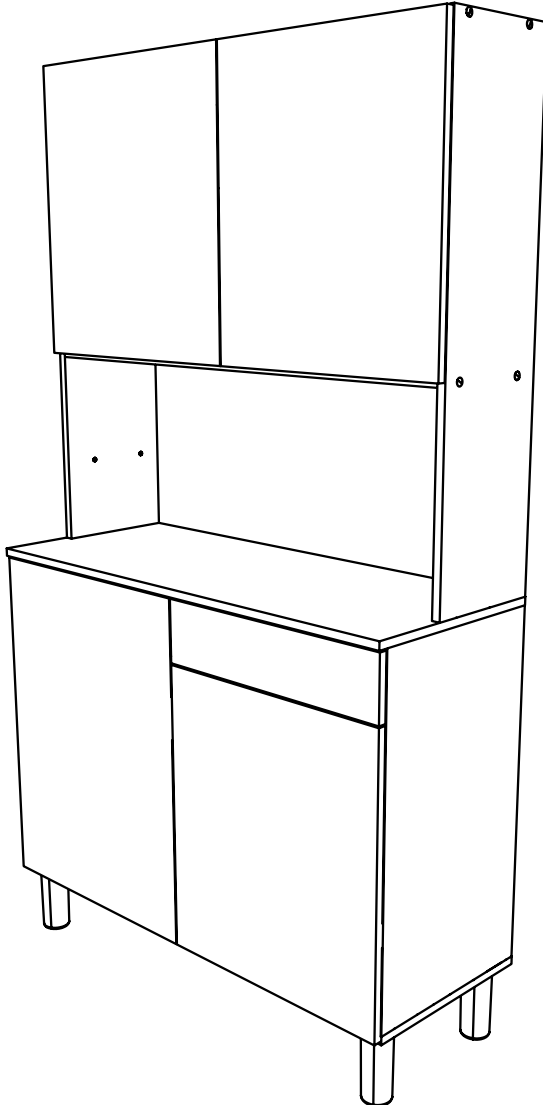

FR Remerciements :

Nous vous remercions d'avoir choisi un meuble créé et fabriqué par Ekipa et espérons qu'il vous donnera entière satisfaction.

EN Thanks :

Thank you for choosing furniture designed and manufactured by Ekipa. We hope you are totally satisfied your purchase.

DE Danksagung:

Wir danken Ihnen den Kauf eines Frankreich von der Ekipa entworfenen und hergestellten Möbelstücks und hoffen, dass Sie es zu Ihrer vollkommenen Zufriedenheit finden werden.

ES Agradecimientos :

Les damos las gracias por haber elegido un mueble diseñado y fabricado por el Ekipa y esperamos que sea de su total agrado.

PT Agradecimientos :

Obrigado por ter escolhido um móvel concebido e fabricado pelo Ekipa, esperando que seja do seu inteiro agrado.

IT Ringraziamenti:

Grazie per avere scelto un mobile progettato e fabbricato dal Ekipa. Speriamo soddisfatti appieno le vostre esigenze.

NL Bedankje:

Wij bedanken u voor de aankoop van een door de Ekipa ontworpen en vervaardigd meubel en hopen dat u er veel plezier aan zult beleven.

CZ Poděkování:

Děkujeme, že jste si vybrali nábytek navrženy a vyrobeny společností Ekipa. Doufáme, že budete svým nákupem naprosto spokojeni.

HU Köszönet:

Köszönjük, hogy a Ekipa által létrehozott és gyártott bútort választott, reméljük, hogy elégedett lesz a termékkel.

PL Podziękowania:

Dziękujemy za wybór mebli stworzonych i wyprodukowanych przez Ekipa. Mamy nadzieję, że będziecie Państwo w pełni zadowoleni z zakupu.

RO Mulțumiri:

Vă mulțumim că ați ales un articol de mobilier conceput și fabricat de Ekipa și sperăm că veți fi pe deplin satisfăcuți de acesta.

RU Благодарность:

Мы благодарим вас за то, что вы выбрали мебель, созданную и произведенную Групп Паризо, и надеемся, что вы будете полностью удовлетворены нашей продукцией.

SK Pod'akovanie:

Ďakujeme, že ste si vybrali nábytok navrhnutý a vyrobený spoločnosťou Ekipa. Dúfame, že budete svojím nákupom absolútne spokojní.

TR Teşekkür ederiz:

Ekipa tarafından tasartanan ve üretilen bu mobilyayı seçtiğiniz için teşekkür ederiz. Ürünümüzden memn kalmahnızı ümit ederiz

AR شكر:

نشكركم لاختياركم هذه المجموعة من الأثاث من تصميم وتصنيع مجموعة باريزو Ekipa ونتمنى أن تتل رضاهكم.

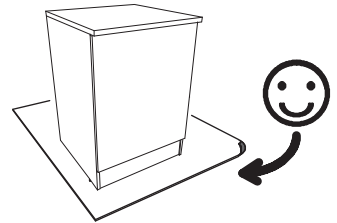
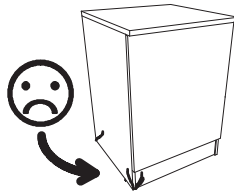
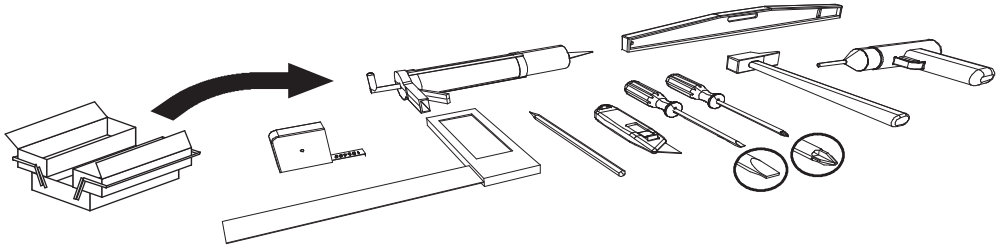



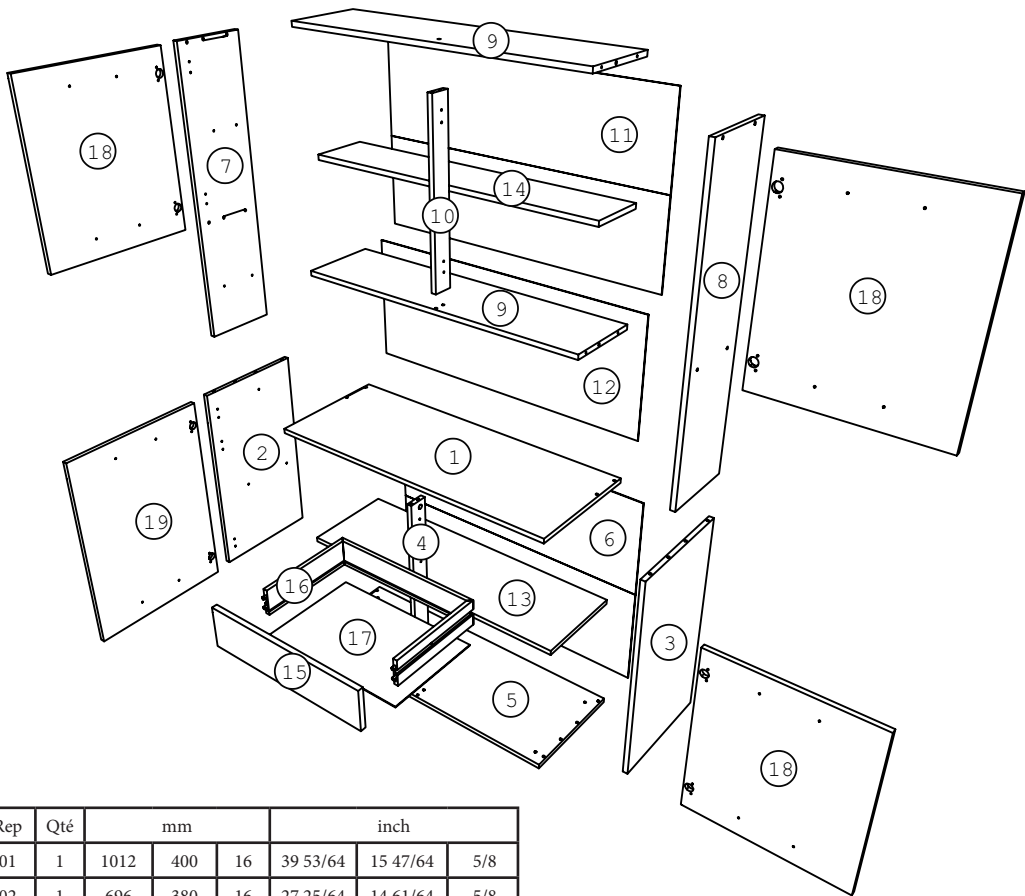







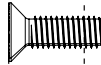

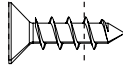

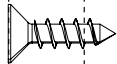

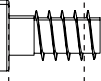

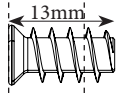

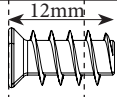

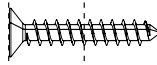



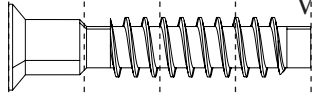

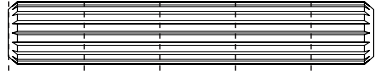

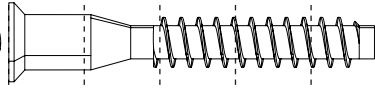

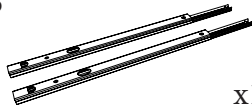



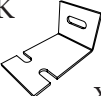
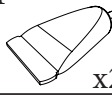

contact@parisot.com

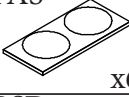
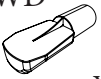

Rep	Qté	mm			inch		
01	1	1012	400	16	39 53/64	15 47/64	5/8
02	1	696	380	16	27 25/64	14 61/64	5/8
03	1	696	380	16	27 25/64	14 61/64	5/8
04	1	696	64	16	27 25/64	2 33/64	5/8
05	1	1012	380,5	16	39 53/64	14 31/32	5/8
06	1	1004	720	2,5	39 33/64	28 11/32	3/32
07	1	978	246	16	38 1/2	9 43/64	5/8
08	1	978	246	16	38 1/2	9 43/64	5/8
09	2	979	245,5	16	38 17/32	9 21/32	5/8
10	1	553,5	64	16	21 25/32	2 33/64	5/8
11	1	1004	576	2,5	39 33/64	22 43/64	3/32
12	1	1004	408	2,5	39 33/64	16 1/16	3/32
13	1	978	315	16	38 1/2	12 25/64	5/8
14	1	978	180	16	38 1/2	7 5/64	5/8
15	1	503	125	16	19 51/64	4 29/32	5/8
16	1	1065	80	12,5	41 59/64	3 5/32	31/64
17	1	451	299	2,5	17 3/4	11 49/64	3/32
18	3	574	503	16	22 19/32	19 51/64	5/8
19	1	702	503	16	27 5/8	19 51/64	5/8

0 1cm 2 3 4 5

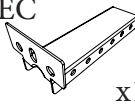
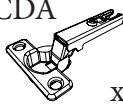
		VR	x4
		VMFI	x1
		VAF8	x4
		VG	x1
		CDS	x32
		FO	x1
		BWF	x4
		WJ	x10
		ADM	x22
		VO1	x4
		AB	x2
		HW	x16

		
CP		x1
FA	HV	CC08
		
x10	x1	x1
PA	CA	ZK
		
x40	x1	x1
CF	OO	PAS
		
x2	x12	x6
BWD	AI	BSD
		
x8	x2	x2
JB	PIED	PB
		
x2	x4	x5
EC	CDA	CDD
		
x1	x8	x8

1

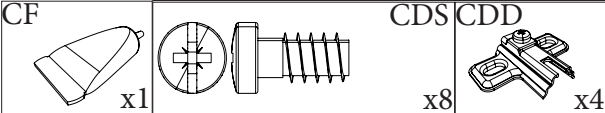
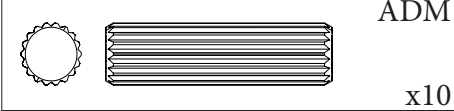
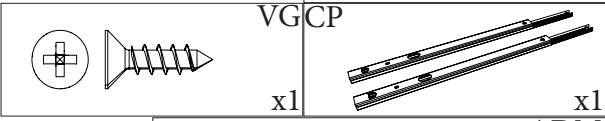
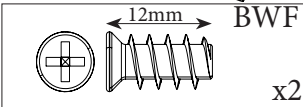
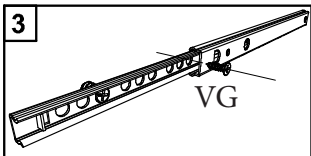
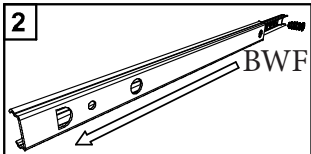
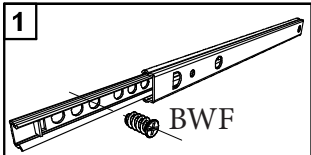
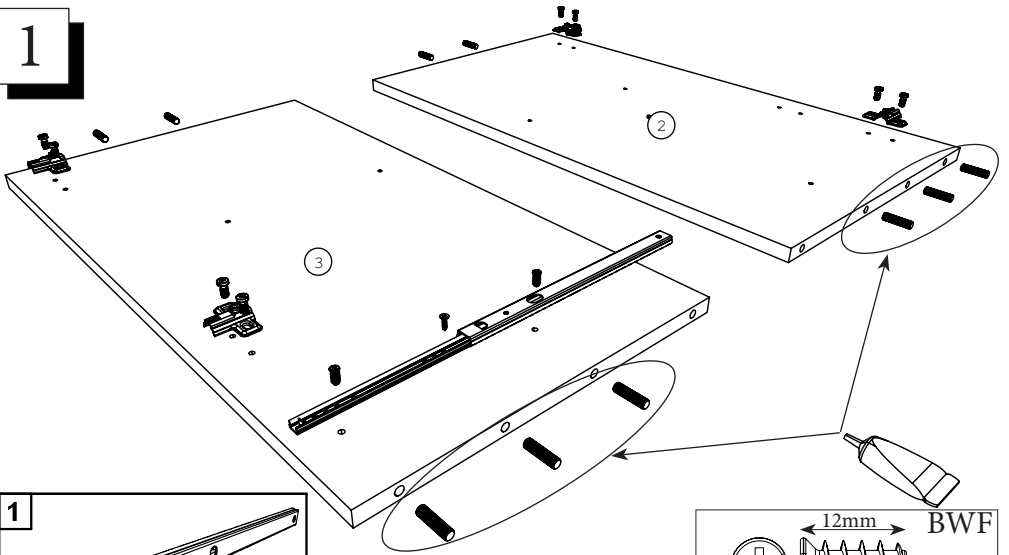

2

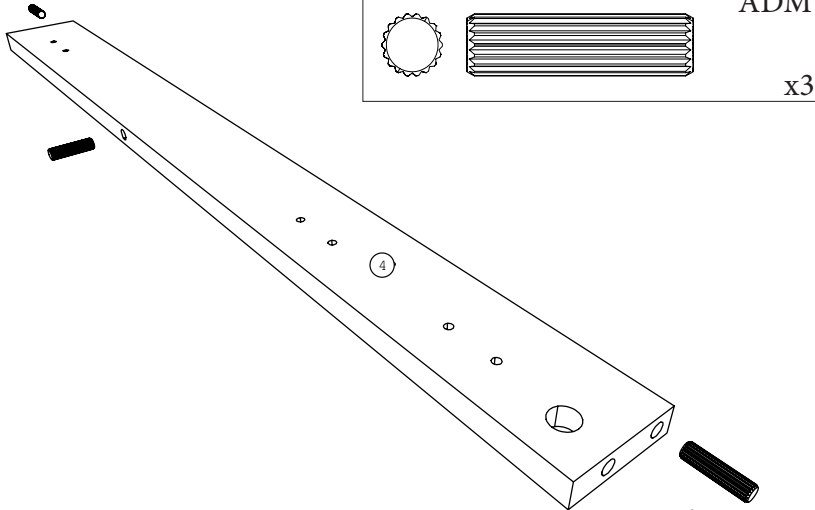

3

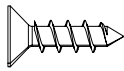

VAF8

x2

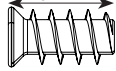

13mm

FOEC

x1

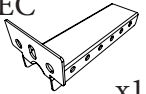

x1

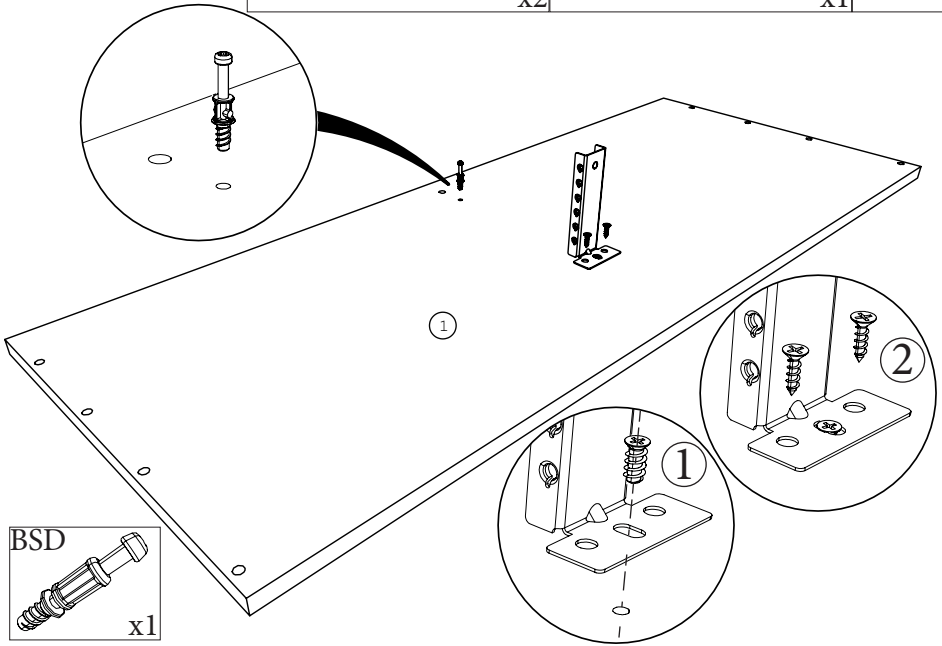

BSD

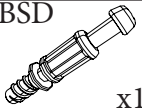

x1

4

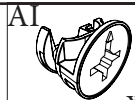

x1

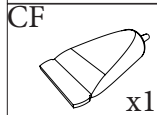

x1

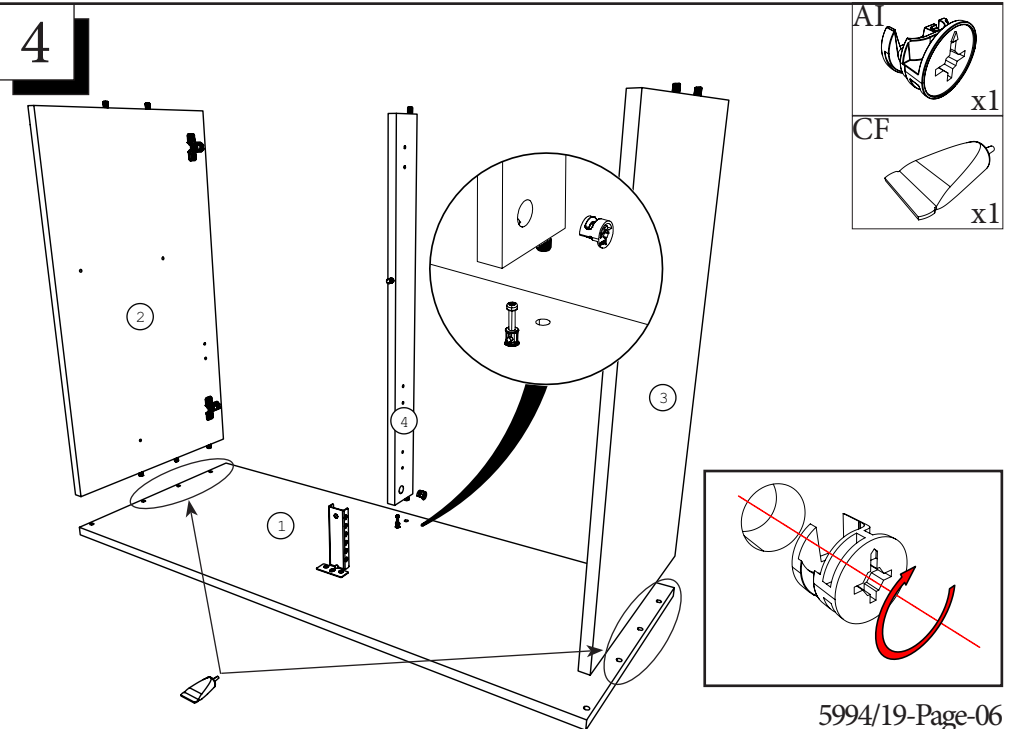

5

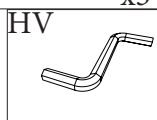
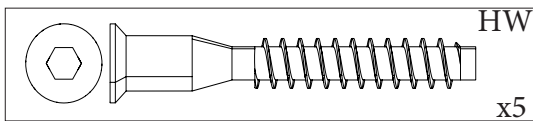
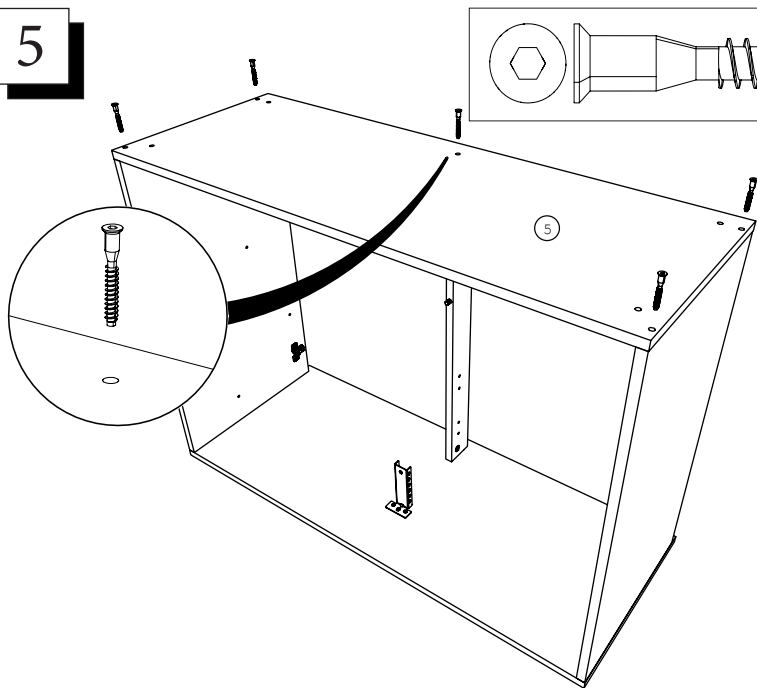

6

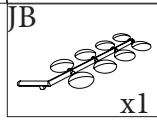
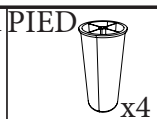
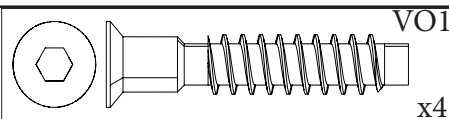
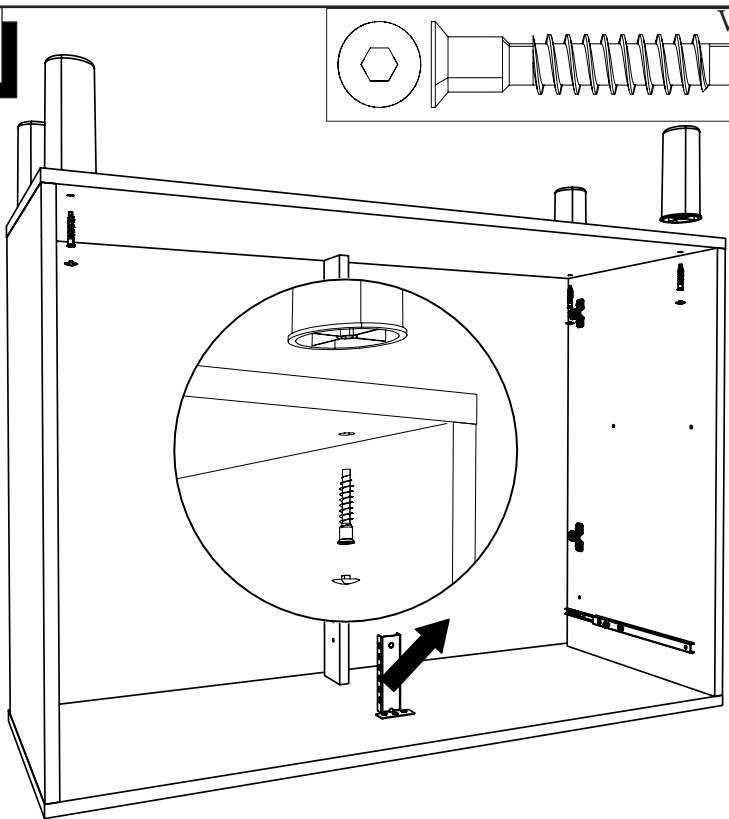

7

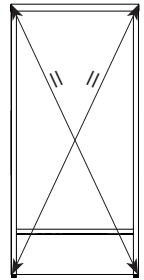
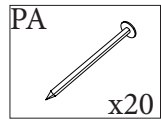
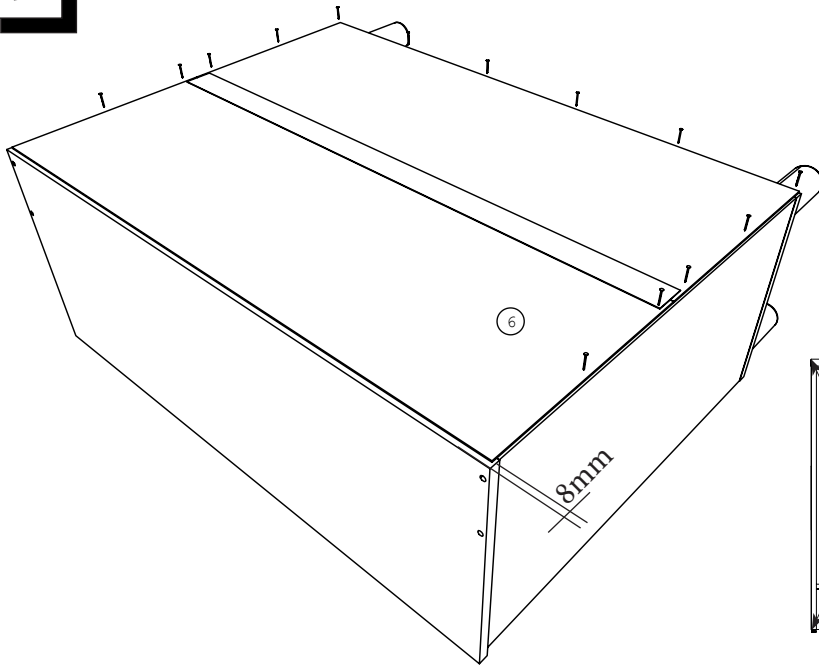

8

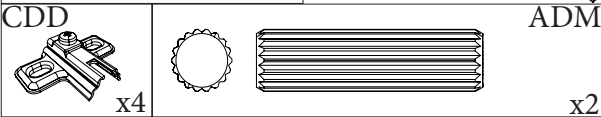
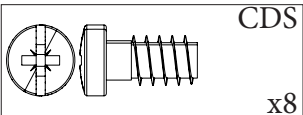
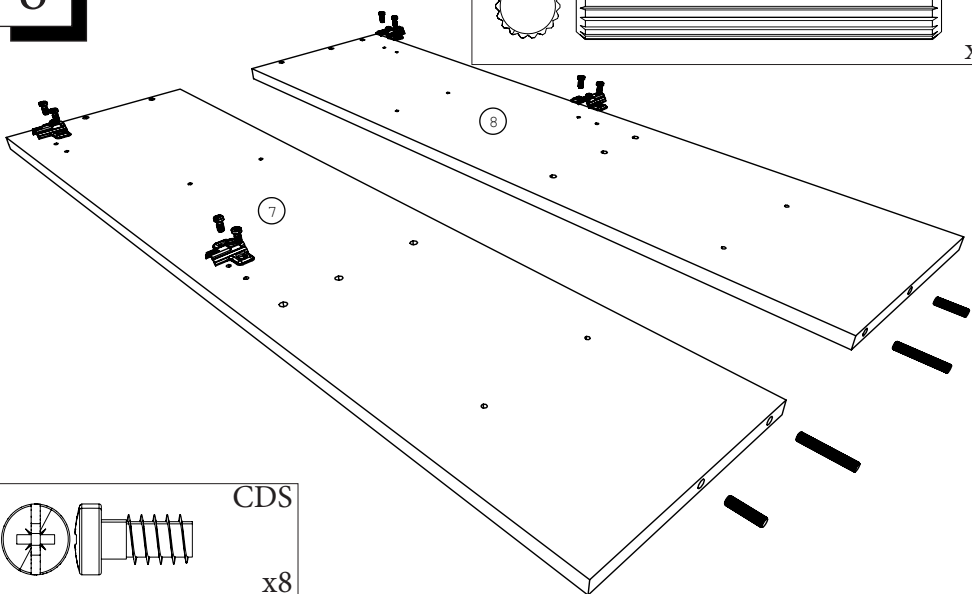

9

ADM
x7

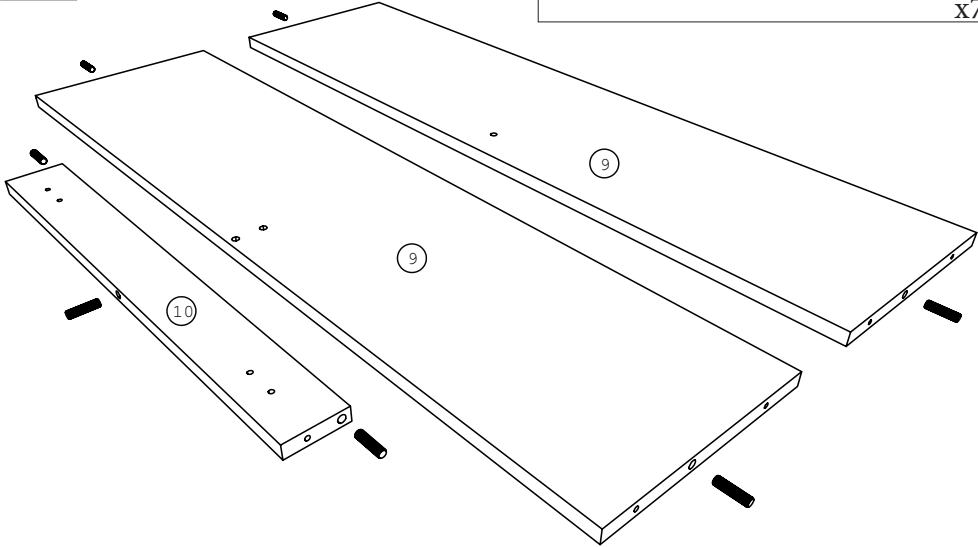
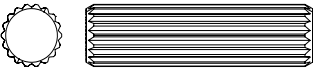

10

HV
HW
x2

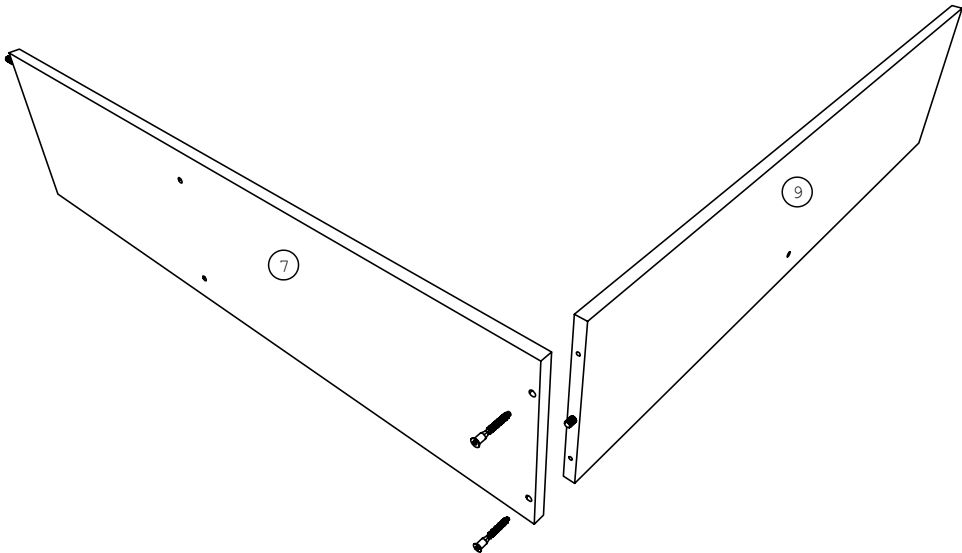
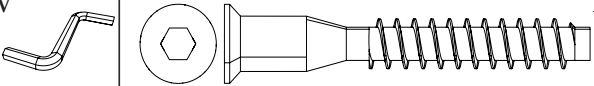

11

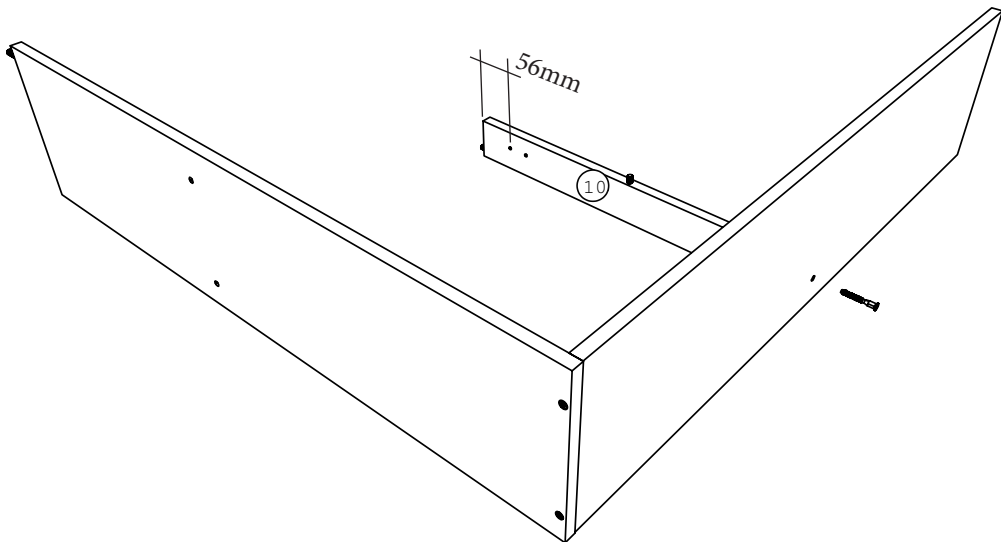
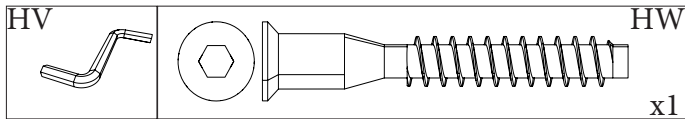

12

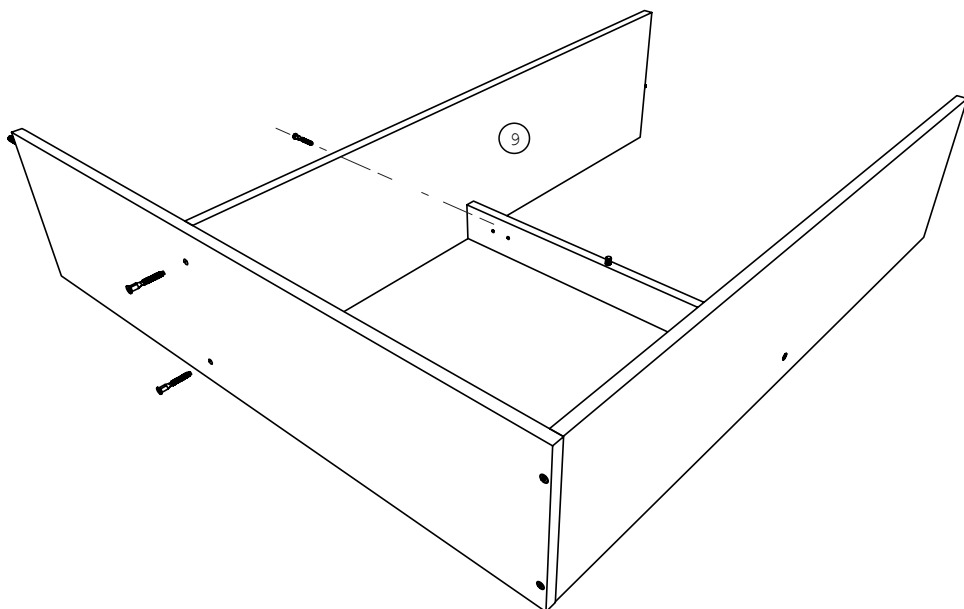
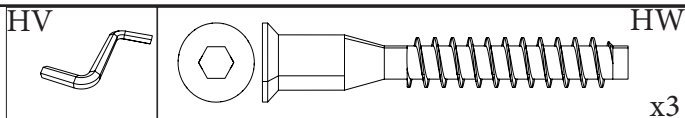

13

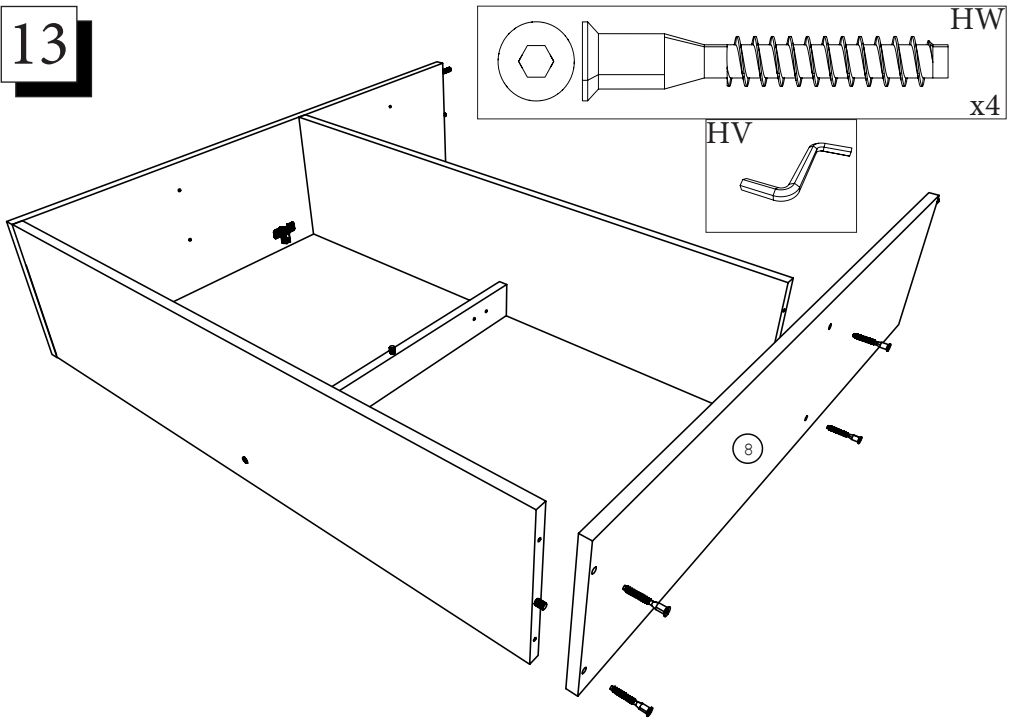

14

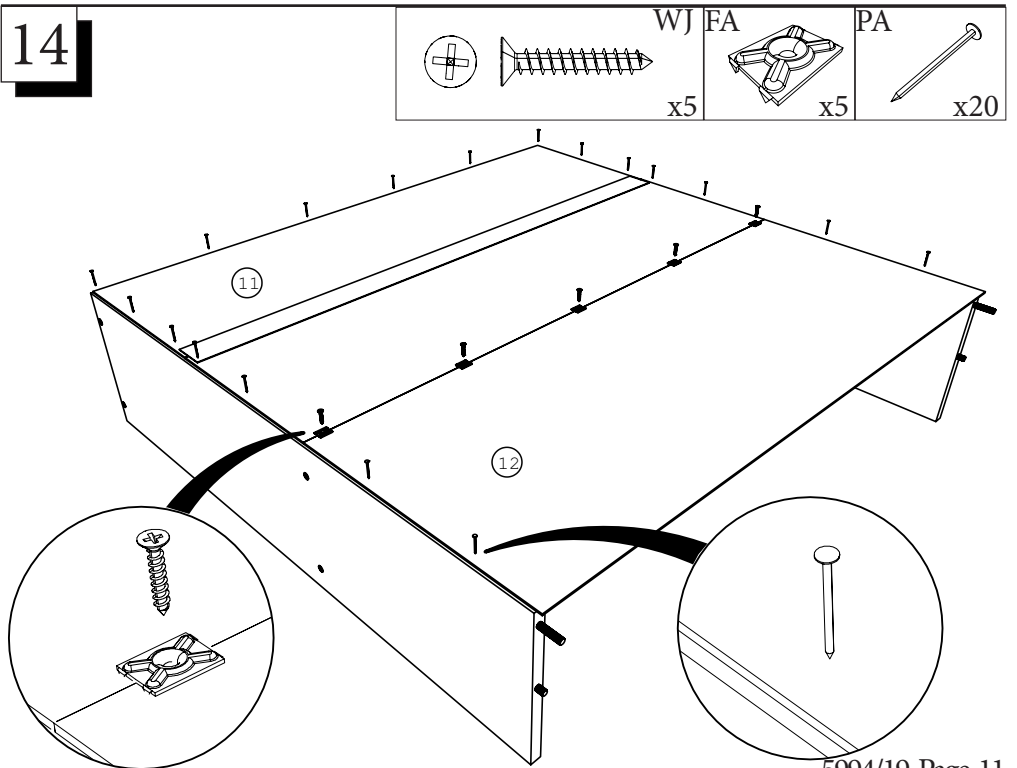

15

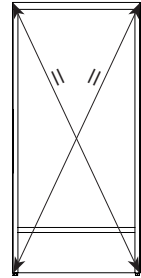
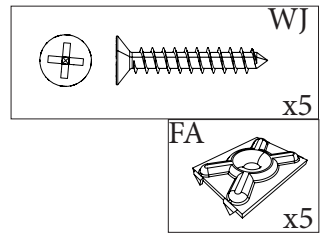
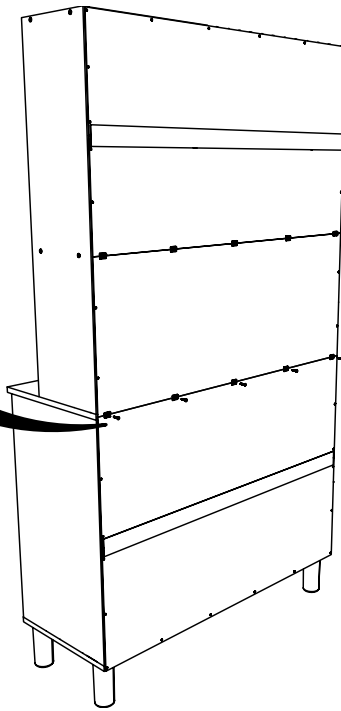
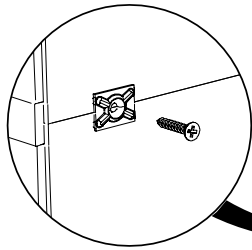

16

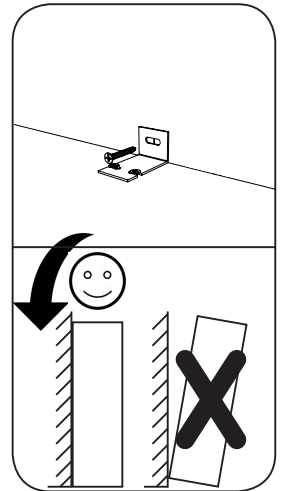
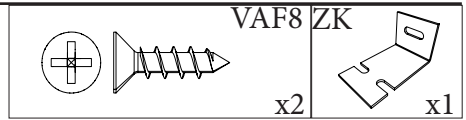
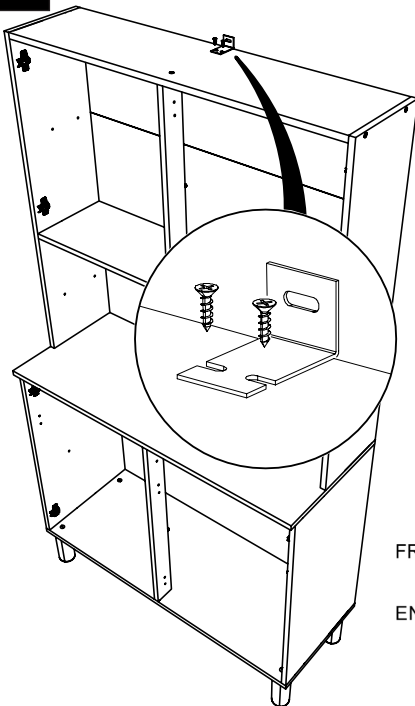

FR Pour votre sécurité : Fixation du meuble au mur
 Attention, la fixation doit être réalisée par une personne compétente car cela nécessite des chevilles adaptées à la nature de votre mur.

EN For your safety: the unit should be secured to the wall.
 NB this should be carried out by a competent person as you must use the right rawplug for your type of wall.

17

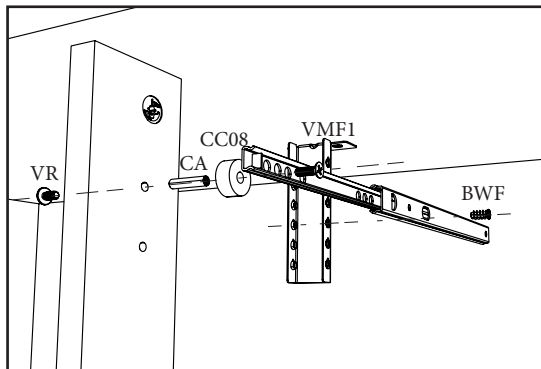
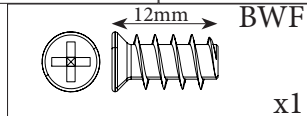
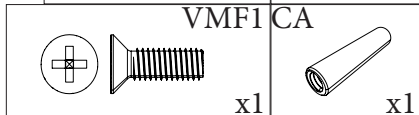
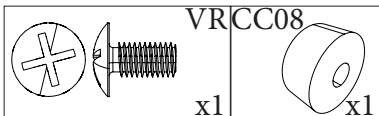
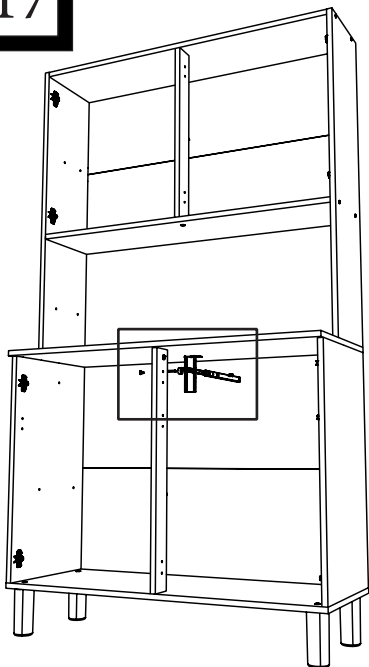

18

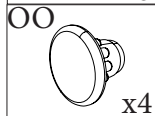
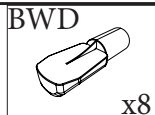
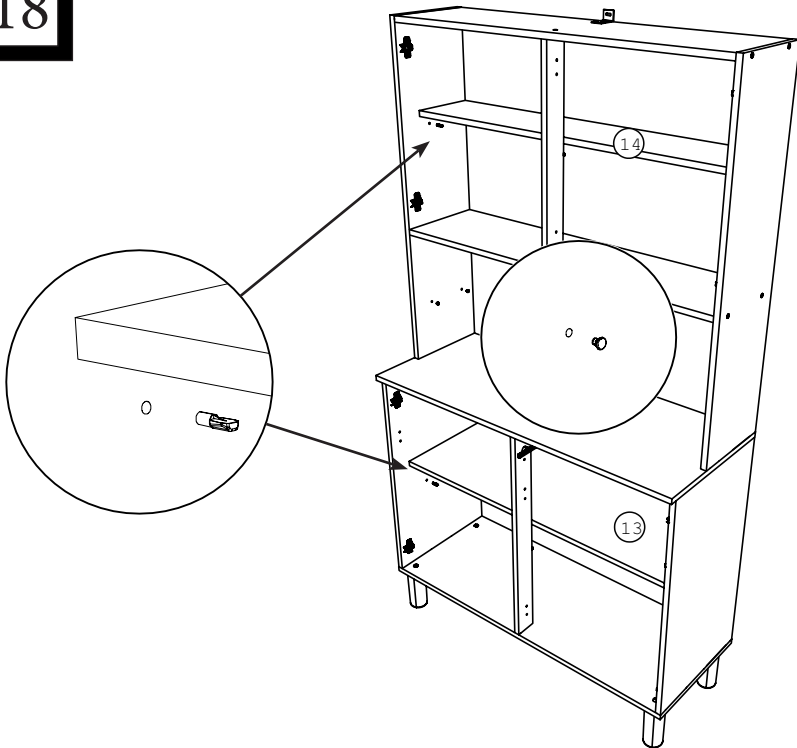

19

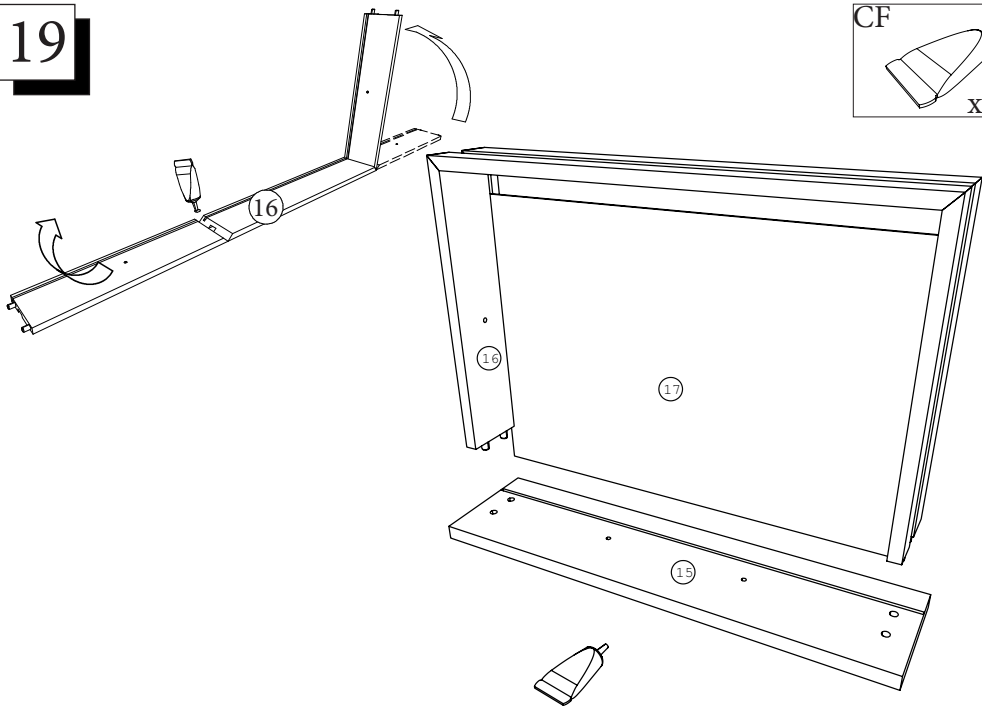
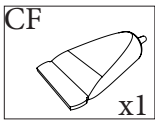

20

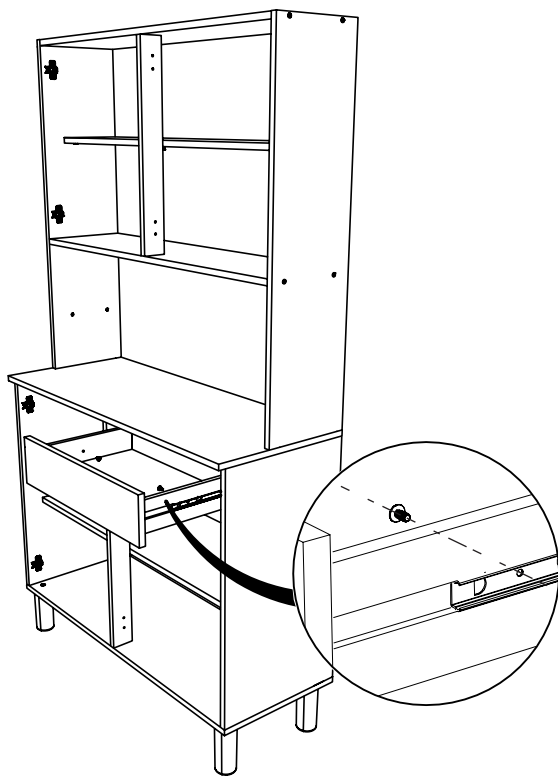
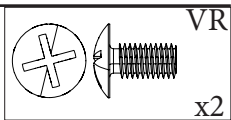

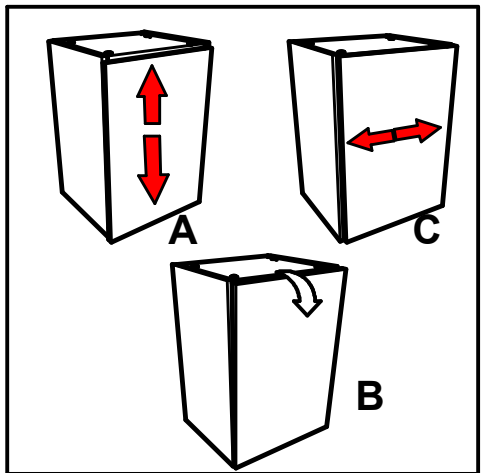
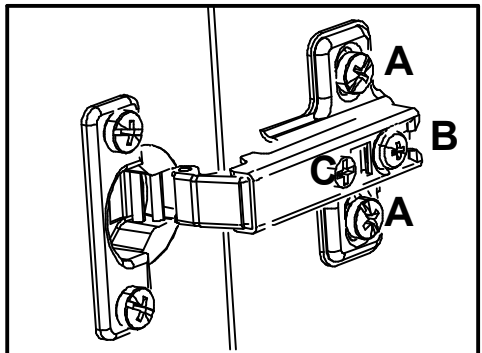
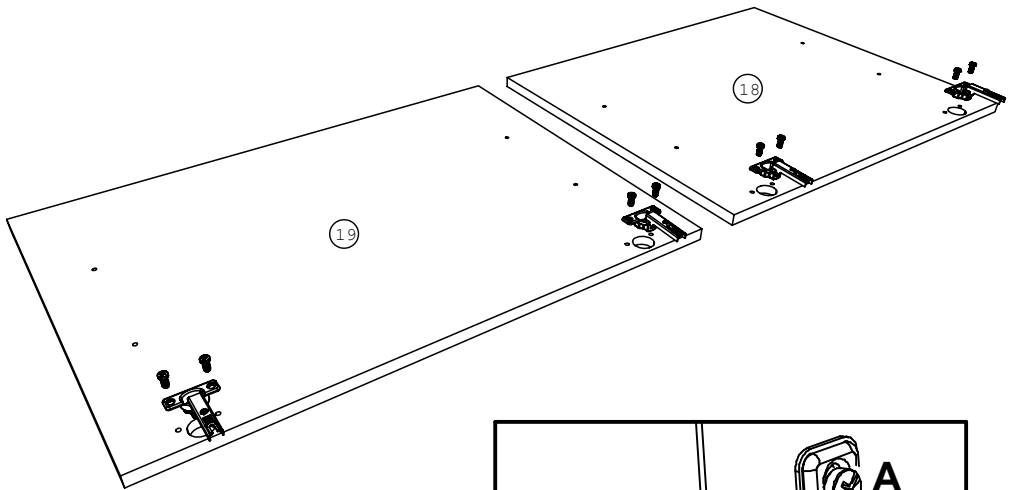
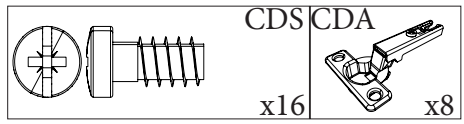

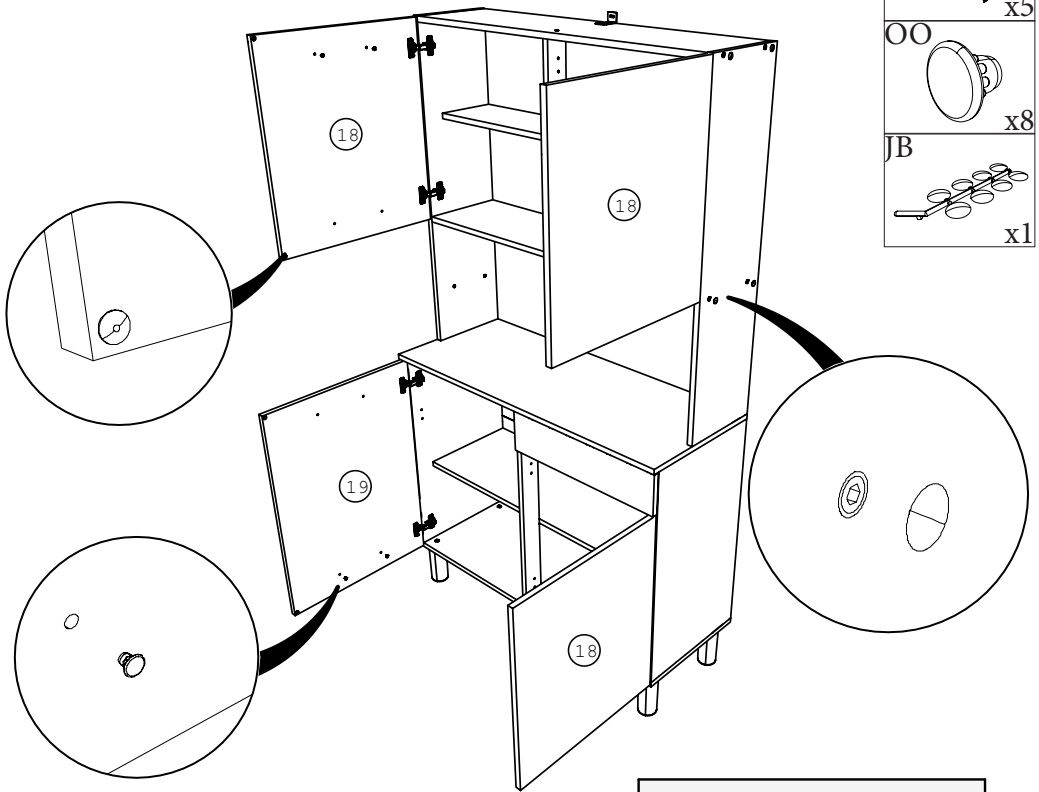

FRANCAIS-SUISSE

POSE DES POIGNEES OU BOUTONS

Déboucher le ou les percages sur la porte si nécessaire après vérification du sens d'ouverture.

Utiliser une chute de bois pour éviter les éclats.

Vérifier la longueur de la vis.

ENGLISH

INSTALLATION OF HANDLES OR BUTTONS

Open the hole(s) on the door if necessary after checking the opening direction.

Use a drop of wood to avoid splinters.

Check the length of the screw.

